

The **Butt Weld (B4, B8)** check valve is a one piece body machined from bar stock, eliminating porosity concerns and providing uniform density for more consistent welds. Made to ASME/ANSI B16.25 for schedule 40 pipe (B4), or schedule 80 pipe (B8) it carries rugged, dependable Check-All® trim with a wide variety of seat materials and cracking pressures to choose from. The Butt Weld valve can also be used as a low pressure relief valve or vacuum breaker by using the desired spring settings.

**CAUTION:** Please take sufficient measures when welding to prevent heat build-up and possible damage to the valve seat. See page 51 for additional installation information.

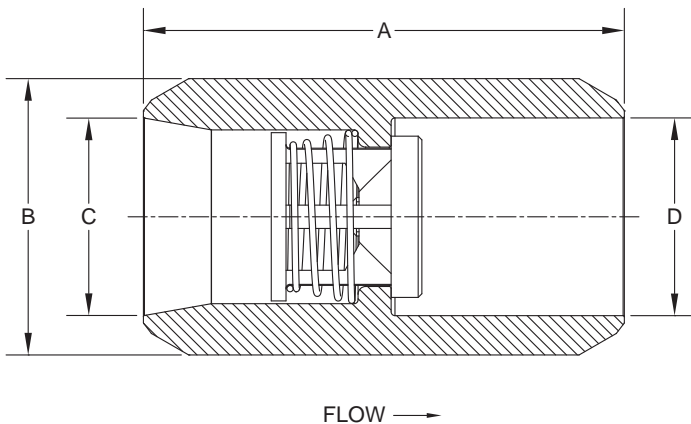

Nom. Pipe Size	Size Code	A	B ①	B4 Valve C & D	B8 Valve C & D	Orifice Diameter
1/2	D	2.16	15/16	0.622	0.546	0.348
3/4	F	2.71	1-3/16	0.824	0.742	0.464
1	H	2.95	1-1/2	1.049	0.957	0.593
1-1/4	I	3.64	1-7/8	1.380	1.278	0.890
1-1/2	J	3.91	2-1/4	1.610	1.500	1.135
2	K	4.36	2-3/4	2.067	1.939	1.385
2-1/2	L	5.00	3-1/4	2.469	2.323	1.555
3	M	5.44	3-3/4	3.068	2.900	2.025
4	N	6.80	4-3/4	4.026	3.826	2.560

① May be larger.

**NOTE:** Many valves in this series can be supplied with B16.34 certification. Consult the factory for more information.

Body Material ②	Availability	Non-Shock Pressure-Temperature Rating			
316/316L Stainless Steel (SS)	Standard	1/2" - 1"	1-1/4" - 2-1/2"	3"	4"
Carbon Steel (CS)					
Alloy 20 (A2)	Semi-standard	5000 PSIG @ 100°F (1500 PSIG for o-ring seats)	4000 PSIG @ 100°F (1500 PSIG for o-ring seats)	3000 PSIG @ 100°F (1500 PSIG for o-ring seats)	1500 PSIG @ 100°F
Alloy C-276 (HC)					
Alloy 400 or Monel® (MO)					
Alloy B (HB)	Contact the factory for these or other materials				

② See page 53 for material grade information.

**Butt Weld Valve**  
For Water at 72°F

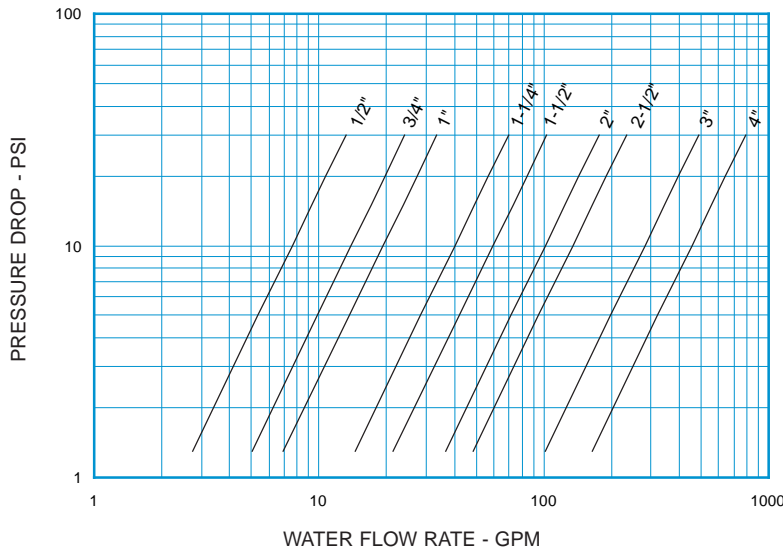

**Note:** All flow curves and Cv values presume the valves are fully open with 1/2 PSI cracking pressure springs. Consult the factory for more information.

STYLE B4 C <sub>v</sub> VALUES & VALVE WEIGHTS		
C <sub>v</sub>	SIZE	SS & CS Alloys
2.4	1/2	4.6 oz.
4.4	3/4	8.8 oz.
6.1	1	14.8 oz.
12.7	1-1/4	1.7 lb.
18.8	1-1/2	2.6 lb.
32.0	2	4.0 lb.
42.5	2-1/2	6.3 lb.
89.0	3	8.3 lb.
144	4	15 lb.

See page 49 for Flow Formulae. Valve weights are approximate.

**HOW TO ORDER  
CHECK-ALL STYLE B4, B8**

**BODY MATERIAL**  
ALLOY 20 = A2  
CARBON STEEL = CS  
ALLOY B = HB  
ALLOY C-276 = HC  
ALLOY 400 OR MONEL® = MO  
316/316L SS = SS  
See p. 3 for temperature ratings

**SPRING CRACKING PRESSURES**  
Replace "X" with actual desired setting. Must use decimal as a character.  
(PSI)      FORMAT      EXAMPLE  
.000 TO .999 = .XXX      .500  
1.00 TO 9.99 = X.XX      1.50  
10.0 TO 99.9 = XX.X      15.0  
NO SPRING = NOSPRG      NOSPRG  
**STANDARD CRACKING PRESSURES ①**  
.125      .500      1.50      3.50  
(Sizes D-J Only)

**Note:** Many other cracking pressures are available. All spring tolerances +/- 15%.

**SPECIAL OPTIONS**  
T = FEP ENCAPSULATED SPRING  
See p. 4 for temperature rating  
Contact the factory for more options

**B**

**VALVE STYLE**  
SCH 40 PIPE = B4  
SCH 80 PIPE = B8

**SIZE**  
1/2 = D  
3/4 = F  
1 = H  
1-1/4 = I  
1-1/2 = J  
2 = K  
2-1/2 = L  
3 = M  
4 = N

**SEAT MATERIAL ②**  
AFLAS® = AS  
BUNA-N = BN  
EPDM ③ = EP  
KALREZ® = KZ  
"METAL-TO-METAL" = MT  
NEOPRENE = NE  
PTFE = TF  
VITON® = VT  
See p. 3 for temperature ratings

**SPRING MATERIAL**  
316 SS = SS  
ALLOY C-276 = HC  
ALLOY B = HB  
ALLOY X750 OR INCONEL® X750 = IX  
ALLOY 400 OR MONEL® = MO  
17-7PH SS = PH  
TITANIUM = TI  
See p. 4 for temperature ratings

Listed above are the most common material selections. Please contact the factory for additional options.

- ① .500 PSI is the only standard cracking pressure for spring materials other than Stainless Steel. .125 PSI springs are not recommended for installations with flow vertical down.
- ② Seat materials other than "metal-to-metal" have a maximum pressure rating of 1500 PSI. "Metal-to-Metal" and PTFE seats are not resilient. See page 50 for allowable leakage rates.
- ③ EP seats not recommended for use with Carbon Steel valves.