

SIDE CLAMPS - WIDE JAW

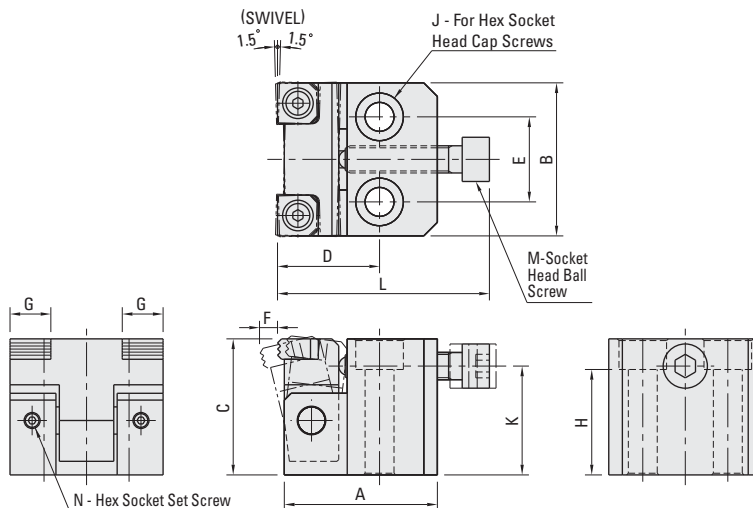
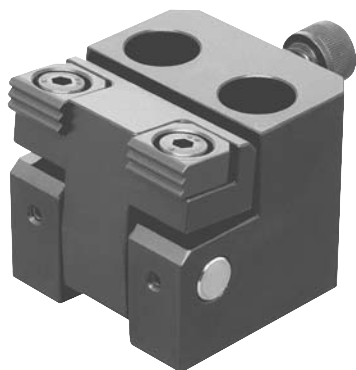

The jaws move forward and downward as the ball screw is tightened. The jaws swivel 1.5 degrees from center to allow for clamping on uneven surfaces. Tightening the ball screw forces the clamp forward and downward against the workpiece supports and stops. The body is made from SAE-1045 alloy steel. The arm is made from SAE-1045 alloy steel, heat treated. The replaceable jaws are serrated for positive holding and are made from M-2 high speed steel, hardened to Rc 60/62. Parts have black oxide finish.

Part #	A mm	B mm	C mm	D mm	E mm	F mm	G mm	H mm	J mm	K mm	L mm	M mm	N mm	Clamping Force lbs.	Screw Torque Ft. lbs.
CP102-08040	45	45	40	30	25	5.3	12	31	M8	32	62.5	M8X1.25	M4X0.7	2470	18
CP102-10050	55	55	50	40	30	7.1	16	39	M10	40	74.0	M10X1.5	M4X0.7	4046	36
CP102-12060	65	65	60	45	35	8.0	20	47	M12	48	91.0	M12X1.75	M5X0.8	5620	66

SIDE CLAMPS

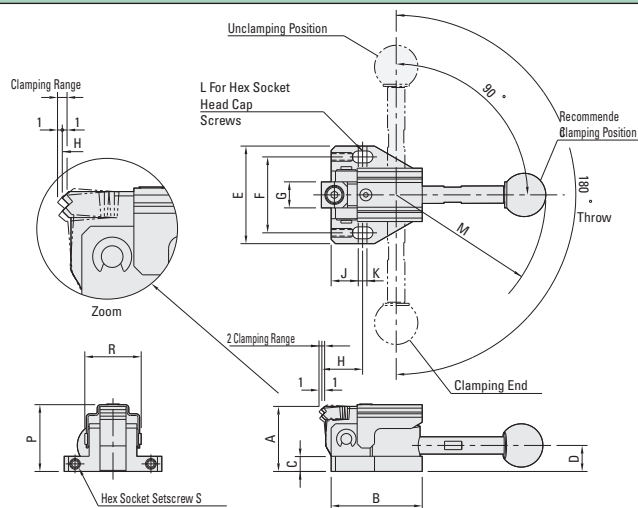

These side clamps have a moving jaw which moves forward and slightly downward for secure workholding. Moving the handle 45 degrees pushes the clamping jaw forward 2mm. When releasing the clamp, the jaws move back for easy insertion and removal of the work piece. The 150 series provides up to 670 lbs of clamping force and the 200 series provides up to 890 lbs of clamping force. User can attach custom jaws to fit special application. These clamps work very well for repetitive clamping operations. The base is made from SAE-1045 alloy steel, heat treated. The replaceable serrated jaw provides positive holding and is made from M-2 high speed steel, hardened to Rc 60/62. Parts have a black oxide finish. The ball knob is black plastic.

With Handle Part #	w/o Handle Part #	A mm	B mm	C mm	D mm	E mm	F mm	G mm	H mm	J mm	K mm	L mm	M mm	P mm	R mm	S mm	Clamping Force lbs.
QLSC150R	QLSC150NR	30	42	7	12	45	35	12	19	12.5	4	M5	69	31	36	M4X0.7	650
QLSC200R	QLSC200NR	40	62	10	16	65	50	16	28	18.5	5	M8	104	31	38	M4X0.7	900