

SWING CLAMPS - HEAVY DUTY

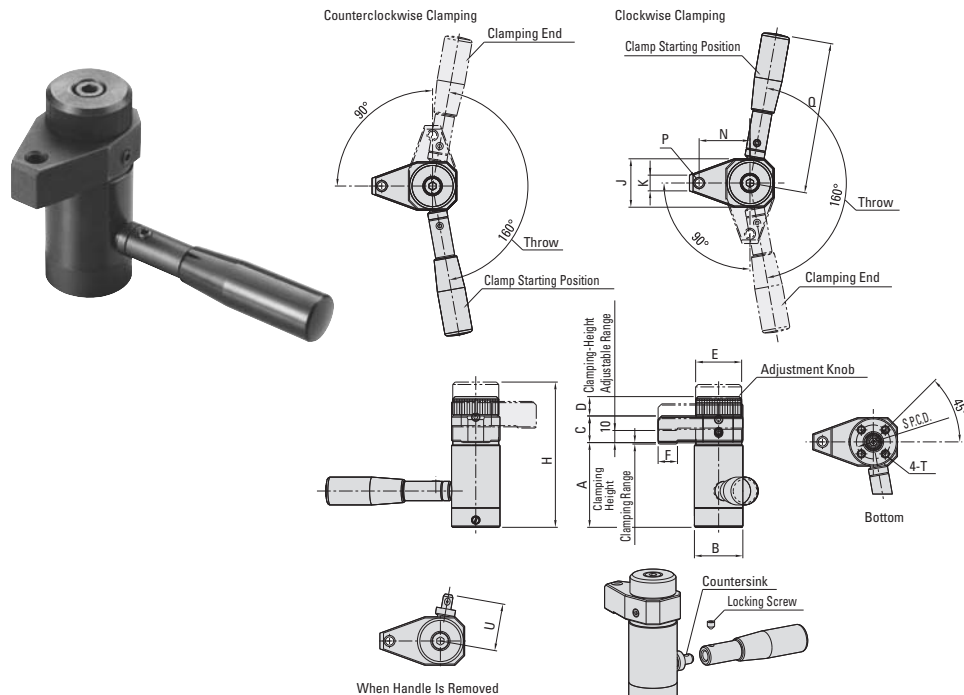

These Heavy Duty Swing Clamps swing into position then clamp straight down onto the work piece for direct downward pressure. The arm swings completely out of the way to allow for easy loading and unloading of the work piece. Ideal for repetitive clamping operations. The tapped end of the clamp arm allows for a clamping tip to be added. Mounts from the bottom with four mounting holes. Mounting bases are available that allow top side mounting. To operate: load the work piece, turn the adjustment knob to rotate and lower the clamp arm over the work piece. Rotate the handle to apply full clamping force to the work piece. The 400 series provide 786 lbs of clamping force, the 500 series provides 1,348 lbs of clamping force. Part numbers ending with R have a clockwise clamping direction, part numbers ending in L have a counter clockwise clamping direction. The body, cam and handle are made from SAE-4140 alloy steel. The clamp arm is made from SAE-1045 alloy steel. Parts are heat treated with black oxide finish. The handle is made from black plastic.

How To Use

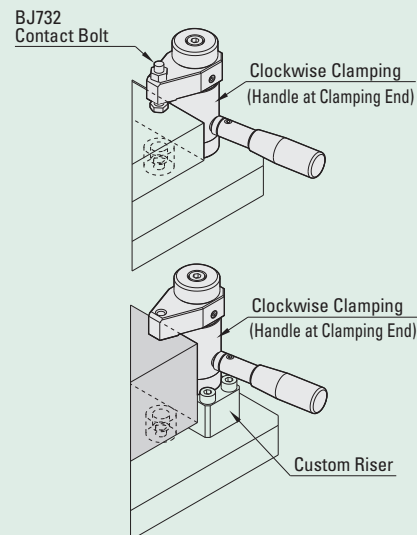

Tip Installation

When installing a tip on the clamp arm, lock the clamp arm using a wrench to prevent the clamp from receiving any torque.

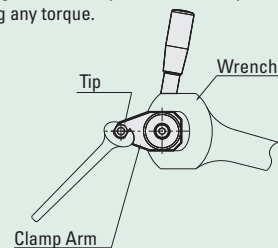

Part #	Clamping Range mm	Clamping Height mm	B mm	C mm	D mm	E mm	F mm	H mm	J mm	K mm	N mm	P mm	Q mm	U mm	P.C.D.* S mm	T mm
QLSWH400R	1.2	70-80	40	22	16	38	16	120	40	13	42	M8X1.25	125	39	28	M6X1X12D
QLSWH400L	1.2	70-80	40	22	16	38	16	120	40	13	42	M8X1.25	125	39	28	M6X1X12D
QLSWH500R	1.6	80-90	50	25	20	48	24	137	50	18	48	M12X1.75	160	47	35	M8X1.25X16D
QLSWH500L	1.6	80-90	50	25	20	48	24	137	50	18	48	M12X1.75	160	47	35	M8X1.25X16D

Note: Maximum load on the handle cannot exceed 134 lbs. *Pitch Circle Diameter

SWING CLAMP MOUNTING PLATES - HEAVY DUTY

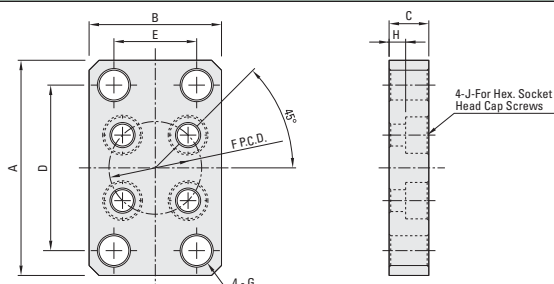

For use with the Heavy Duty Swing Clamps shown above. The plates attach to the swing clamps and allow for easy fastening and top side mounting. Can also be used to adjust the height of the swing clamp. Made from SAE-1045 alloy steel with black oxide finish.

Part #	A mm	B mm	C mm	D mm	E mm	P.C.D.* F mm	G mm	H mm	J mm	Use with Clamp Series
QLSWH400-P	65	40	12	50	25	28	9	5	M6	QLSWH400
QLSWH500-P	85	50	16	65	30	35	11	7	M8	QLSWH500

*Pitch Circle Diameter