



Powerful ■ Portable ■ Economical ■ Made in the USA



U.S. Patent #7,550,021 B2
 U.S. Patent #D604,464 S
 U.S. Patent #8,491,686
 Flame Guard Pat. #8,496,719
 Dust Sentry™ Pat. #8,514,090

Appearance may vary slightly.

The 2hp Dust Gorilla Portable™
1.800.732.4065 Dust Collector Quote Sheet www.oneida-air.com

Oneida Air Systems, Inc. was founded in 1993 to bring cost effective, state-of-the-art dust collection systems and material handling ductwork to woodworking shops. OAS designs and manufactures industrial grade dust collection systems that create a practical, safe and healthy work place environment.

The Oneida Advantage

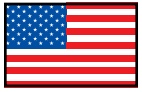

Made in the USA!

Our entire system is ETL safety certified.



The Dust Gorilla Portable™ Collector is the Subject of 5 Patents:

1. U.S. Patent #7,550,021 B2 / June 2009 / Portable Cyclonic Dust Collection Technology
2. U.S. Patent #D604,464 S / Nov 2009 / Portable Cyclonic Dust Collection Technology
3. U.S. Patent #8,496,719 - Flame Guard Arrestor Technology for Fire Safety
4. U.S. Patent Application Docket # 690.030PA September 20, 2010 / 2010 Dust Sentry - Bin Level Sensor
5. U.S. Patent #8,491,686 / July 23, 2013 / Clamp-Raised Dust Barrel

① Filter

GE Certified (H-12) HEPA Media / MERV 16+ Rated - see spec sheet on website



Flame Guard Arrestor Pat. #8,496,719

Drop in Silencer Element.

② Dust Drum

35 Gallon Steel Drum with Casters. Drops down for easy removal and emptying.

Optional Bag Liner Hold-Down shown.

③ Internal Silencer

Built in Silencer reduces sound to 73 - 74 dBA @ 10'. Patented design.

④ Dust Sentry™ - Full Bin Indicator Light and Sensor

The Dust Sentry won the 2010 Handy Innovation Award.

Lets you know when it's time to empty your drum.



⑤ Motor

U.S Made TEFC Motor 2 hp, Class F

⑥ Remote Control

No line of sight required. Extra remotes available.

Shown with optional plastic bag hold-down.

The new Oneida Air Systems 2hp Dust Gorilla Portable™ dust collector offers you power and mobility at an economical price.

Included with this collector are:

The patent pending Dust Sentry™, an infrared bin level indicator that signals you with a flashing strobe light when the 35 gal. dust drum should be emptied without having to take the drum lid off and visually checking the waste level.

The Filter Flame Guard Arrestor for additional safety.

The internal silencer to help make our systems some of the quietest on the market.

GE H12 certified HEPA filter media to make our filters the best you can possibly use.

And of course, Oneida quality comes standard with every made in America dust collection system we produce.

New! 2hp Dust Gorilla Portable™ Collector

Part #	Description	Price
XXP990201H	2hp Dust Gorilla Portable™ Dust Collector	\$2,369.00

Included

- ▶ Flame Guard Arrestor - Pat. #8,496,719
- ▶ Bin Level Indicator
- ▶ Internal Silencer

Filter Media

- ▶ GE Certified (H-12) HEPA Media / MERV 16+ Rated - see spec sheet on website

Dust Bin

- ▶ 35 Gallon Heavy Steel Drum with **casters**. Drops down for easy removal and dumps in seconds.

Motor

- ▶ 2hp Motor / 220V Power Supply
- ▶ Made in the USA

*Oneida reserves the right to change or modify specs and system appearance without notice. Actual system appearance may vary.

2hp Portable Collector Single Cyclone Style

CFM	SP @ Inlet	Tested Amps	dBA @ 10' w/ Silencer
890	1.6	10.8	73.0
739	4.0	10.4	74.0
618	5.1	10.0	73.0
467	7.3	9.4	73.0
405	8.5	8.9	73.0
0	10.5 ^{Max S.P.}	6.6	73.0

with 10' of 4" Flex Hose - 440 CFM

with 10' of 5" Flex Hose - 620 CFM



Included:

Dust Sentry™

2010
HANDY
MAGAZINE
INNOVATION
AWARD

Dimensions

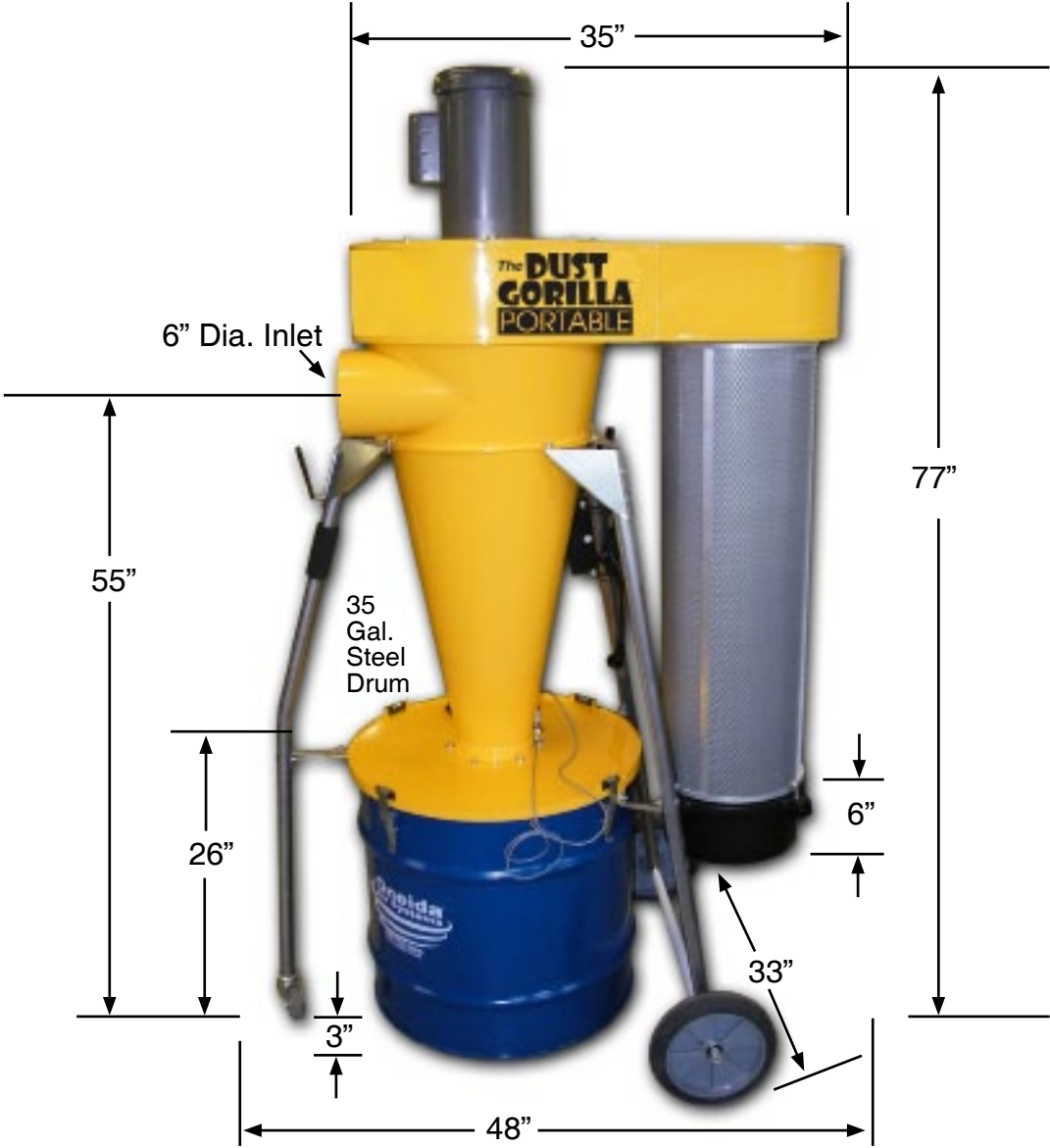

These ductwork kits were designed by Oneida to take the guesswork out of ducting your dust collector and to save you time and effort.

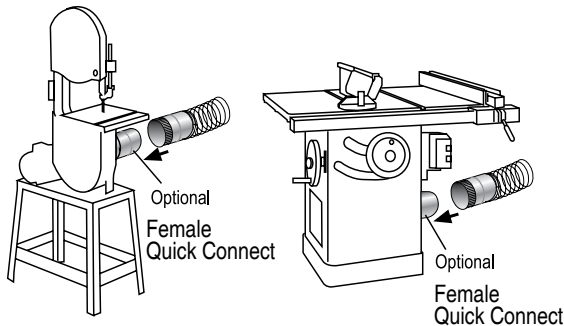

Basic Starter Duct Kit 1

Ductwork Kit #1 for 6" Inlet

Package #1 - KDZ000003

Can be attached to single tools during use.

Included in Package

- (2) Band Clamps 3" to 6" - ACB060000
- (1) Spiral Adapter 5" - DAS050000
- (20 ft.) 5" Flex Hose - DHF050000 .
- (2) Female 5" Quick Connect - DQF050000
- (1) Male 5" Quick Connect - DQM050000
- (1) 5" to 4" Reducer - DRL050400
- (1) 6" to 5" Reducer - DRL060500

Total - Approx. \$186.00*

Basic Starter Duct Kit 2

Ductwork Kit #2 for 6" Inlet

Package #2 - KDZ000004

Can connect tools at two locations near your collector.

Included in Package

- (4) Band Clamps 3" to 6" - ACB060000
- (2) Blastgate Adapters 5" - DAB050000
- (1) End Cap 5" - DCZ050000 .
- (2) 90 5" Adjustable Elbows - DEA900500
- (2) 5" Dia. Aluminum Blast Gates - DGA050000 .
- (20 ft.) 5" Flex Hose - DHF050000 - DHF050000
- (1) 6"x 60" 26 ga. Pipe - DPT260660.
- (1) 5"x 60" 26 ga. Pipe - DPT260560
- (4) Female Quick Connect 5" Dia. - DQF050000
- (2) Male Quick Connect 5" Dia. - DQM050000
- (3) 5" to 4" Reducer - DRL050400 .
- (1) 5x5x5 45 Deg. Wye - DWS050505
- (1) 6x5x5 45 Deg. Wye - DWS060505

Total - Approx. \$443.00*

***Call Oneida for exact pricing.**

General Guidelines for an Efficient Duct System

Metal Duct Gauge

Caution: Sheet metal fittings can have sharp edges.

Small custom shops do well with 22 - 26 gauge pipe fittings. Thinner gauges (such as HVAC pipe) can collapse under fan pressure or dent too easily. Shorter and more direct pipe runs are best and will deliver more air volume to the woodworking machine. Elbows and turns should be kept to a minimum. Use large radius elbows, with a center line radius at least 1.5 times the diameter.

Flex hose connections to machines can be the simplest and easiest way to connect your machines to the metal duct. Flex hose creates more air resistance than metal pipe. Use short lengths of flex hose for connecting to machines. Use wire wrapped helix flex hose for static grounding, bare the ends so they contact the metal pipe. Blast gates can be used at every machine to control air flow.

Use 45 degree wye branches, not 90 degree tee branches. A wye branch has 4x the efficiency of a tee. A 45 degree wye with a 90 degree elbow adjusted to 45 degrees will create a gentle sweep that can be used as a vertical drop or as a right or left turn off of the main duct line. Seal all ducting. Silicone makes a good sealant. Even small cracks can create significant air loss.

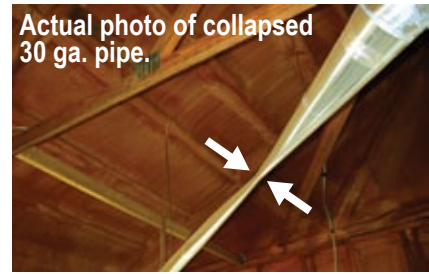

Large Radius Elbow

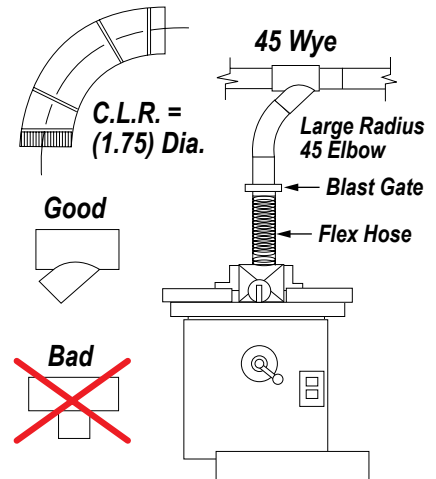

Accessories



No line of sight required.
Radio frequency.

Remote Control Switch

Part #	Description	Price
AMR000000	Extra Transmitter	\$34.75



Filters are easily cleaned by blowing from the outside with compressed air.

Replacement Filters

Part #	Description	Price
FCS133695HF	GE Certified (H-12) HEPA Media / MERV 16+ rated with Flame Guard Arrestor	\$340.00

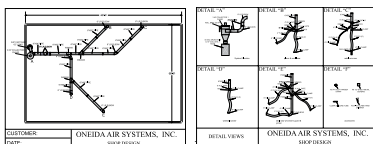

Ductwork Design Service

Part #	Description	Price
MES000000	Ductwork Design Service	\$200.00



Drum and plastic bags not included.

2.5" Cleanshop Accessory Kit

Part #	Description	Price
ASK000000	Cleanshop Accessory Kit	\$143.00

Drum Liner Holder

Part #	Description	Price
ABX000035	Drum Liner Holder Kit	\$48.00

Let OAS help you design your dust collection system

Ductwork Design

With a system purchase and the placement of a refundable shop plan design fee, engineers and qualified technicians will size and design a custom dust collection system complete with ductwork layout including the proper pipe dimensions to run to each piece of equipment.

Trained sales technicians are available to answer questions: 1.800.732.4065

Ductwork Estimate:

Snaplock pipe & Components (24 - 26 gauge) is available with this system and costs approximately \$200 - \$225.00 per woodworking tool port. Average cost estimate for ductwork:

$$(\text{\# of Machines}) \times \$200 - \$225.00 = \text{Ductwork Estimate 24 - 26 Ga. ductwork}$$

Spiral pipe (24 Ga.) and heavy elbows are available with this system and costs approximately \$300 - \$325.00 per woodworking tool port. Average cost estimate for ductwork:

$$(\text{\# of Machines}) \times \$300 - \$325.00 = \text{Ductwork Estimate 24 Ga. spiral pipe \& heavy gauge elbows}$$

Shipping:

Snaplock shipping is free on \$200+ ductwork order / 48 states / Some restrictions apply.

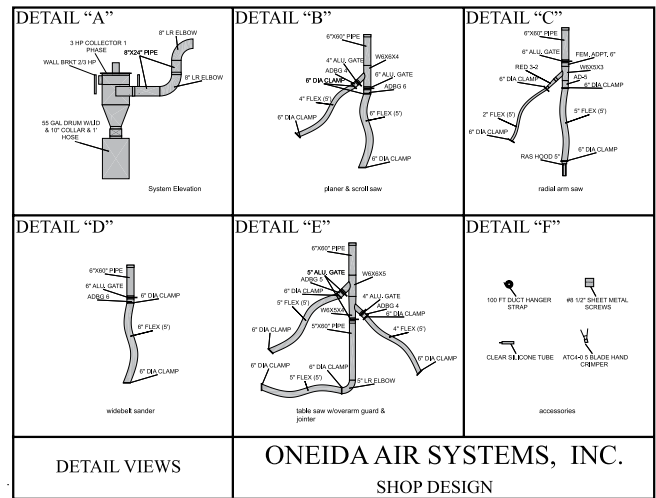
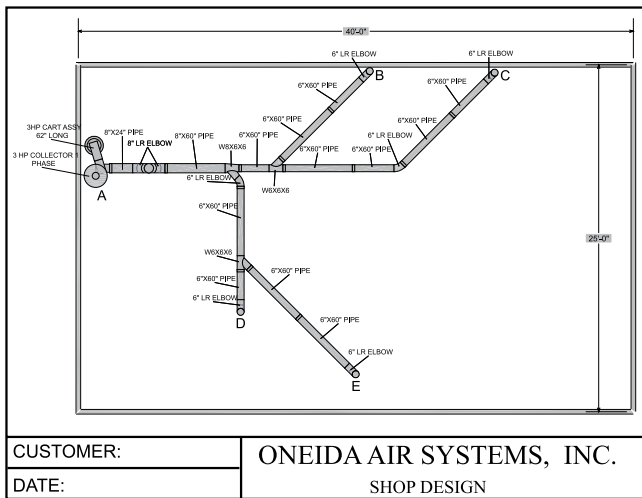

**Ready-to-Ship
Ductwork**



"Service was always great. One of the main reasons I chose Oneida was for the design service and it was all that I hoped for. I felt that the system recommended to me was exactly what my shop needed."

- R.W.

Items Not Covered By Quote

1. Control System: Panels, wiring, system control, breaker or starters unless noted in this quotation.
2. Freight cost, custom fees, duty or loading of freight unless noted in this quotation.
3. Federal, state, municipal or other government excise, sales, use occupational or other like taxes now in force or to be enacted unless noted in this quotation.
4. All labor required for installing the equipment.
5. Anything not specifically mentioned in this quotation.
6. Oneida Air Systems, Inc. reserves the right to void this quote in the event of a typing error or gross oversight.

WARRANTY	WARRANTY	WARRANTY	WARRANTY
90 Days	1 Year	2 Years	5 Years
Dust Deputy's Bag Gripper Remote Control Electronic Items	V - Systems Dust Cobras Mini-Gorillas	Smart Portables Gorilla Portables Super Dust Gorillas Hi-Vac Systems Direct Drive Systems Pulley Drive Systems	Pro 1500 / 2000 Smart Pro Systems* (*2 Yr. Motor Warranty)

Terms and Conditions / Shipping

Oneida tries to ship orders out in a timely manner, however sometimes delays and back orders are inevitable. Oneida will not be held responsible or liable for these conditions or the way they may effect your production. Back orders will be shipped when they are available. When orders are shipped UPS, UPS will notify you by e-mail. If shipped by Common Carrier, you can arrange for the trucking company to notify you and make arrangements for delivery. Shipping method is determined by Oneida Air Systems and is dependent upon material to be shipped and destination. You are not charged until your order is shipped.

► **Checking in Order**

Please look over the shipped order very carefully in the presence of the delivery person for damage or incomplete shipment before signing the delivery receipt. Please note any tears or irregularities in shipping packaging, however slight, on the shipping delivery receipt. This could be an indication of extensive concealed damage. The shipping company will not take responsibility if the damage is not noted on the delivery receipt. In the event of shipping damage, call OAS Customer Service immediately at 1.800.732.4065 so we can expedite replacements. Please check in all parts within 3 days from receiving order. Notify OAS immediately of any missing or incorrect parts. OAS does not accept any claims for damage or shortage after 3 days from date of delivery.

► **Limited Warranty**

Oneida Air Systems™ warrants the products manufactured by Oneida Air Systems, for a period of 1 or more years depending on the product, to the original purchaser from the date of purchase unless otherwise specified. Items not manufactured by Oneida Air Systems are limited to their own manufacturer's warranties. All electrical items such as magnetic starters, remotes, sensors, pumps and accessories are limited to 90 days. Oneida Air Systems warrants that the product will be free from defects in materials and workmanship. This warranty does not apply to defects due directly or indirectly to misuse, negligence, accidents, abuse, repairs, alterations, improper wiring or lack of maintenance. This is Oneida Air Systems sole written warranty and any and all warranties that may be implied by law, including any merchantability or fitness, for any particular purpose, are hereby limited to the duration of this written warranty. Oneida Air Systems does not warrant or represent that the merchandise complies with the provisions of any law or acts unless the manufacturer so warrants. In no event shall Oneida Air Systems' liability under this warranty exceed the purchase price paid for the product and any legal actions brought against Oneida Air Systems shall be tried in the State of New York, County of Onondaga.

ONEIDA AIR SYSTEMS SHALL IN NO EVENT BE LIABLE FOR DEATH, INJURIES TO PERSONS OR PROPERTY OR FOR INCIDENTAL, AND CONTINGENT, SPECIAL, OR CONSEQUENTIAL DAMAGES ARISING FROM THE USE OF OUR PRODUCT.

► **Safety Warning - Please Read**

Before Purchasing or Installing a dust collection system the buyer is cautioned to do so in accordance with prescribed Federal, State, Local, OSHA, NFPA, and any other applicable codes or regulations relating to the type of dust(s) you are collecting.

SOME TYPES OF DUST UNDER CERTAIN CONDITIONS HAVE THE POTENTIAL TO BE EXPLOSIVE.

Oneida Air Systems is not responsible for how the dust collector is used or installed. Dusts with deflagration or explosion risks, such as wood dust, may require additional safety equipment including but not limited to; venting, spark detection, suppression systems, back draft dampers or may require installation in an outside location or in a protected area away from personnel. The customer assumes the responsibility for contacting their insurance underwriter with regard to specific engineering controls or application requirements. (We suggest you reference NFPA 664, 654 and 68 codes for more information) Oneida Air Dust Collection Systems may not be suitable for some applications and are not designed to be used in explosive atmospheres. **Oneida Air Systems equipment should only be installed and wired by a licensed electrician following all applicable local and national electrical codes.**

Some dust created by power sanding, sawing, grinding, drilling, and other construction activities contains chemicals known to cause cancer, birth defects or other reproductive harm. Some examples of these chemicals are:

- Lead from lead-based paints.
- Crystalline silica from bricks, cement and other masonry products.
- Arsenic and chromium from chemically-treated lumber.

Your risk from these exposures varies, depending on how often you do this type of work. To reduce your exposure to these chemicals, work in a well ventilated area, and work with approved safety equipment, such as those dust masks that are specially designed to filter out microscopic particles. Oneida Air Systems recommends using additional approved safety equipment such as an approved OSHA and NIOSH dust mask or respirator.

Oneida Air Systems makes every effort to accurately represent our products, specifications and prices; however Oneida Air Systems reserves the right to make changes to products and prices at any time. As a manufacturer, Oneida Air Systems reserves the right to change product designs and specifications at any time.

► **Delivery Risk of Loss**

Products will be shipped to Buyer's single destination. Title and risk of loss shall pass to the Buyer upon delivery to such destination. Buyer pays transportation expenses. Dates of shipment are advisory and Oneida Air Systems will make reasonable efforts to ship on or before the date states for shipment, however, Oneida Air Systems shall not incur any liability for failure to ship on that date.

► **Returned Goods Policy**

Buyer must inform Oneida Air Systems of any shortage or damage, by so noting in writing, on the freight delivery bill prior to signing to indicate receipt of shipment. All claims covered under the limited warranty, are subject to inspection and investigation by Oneida Air Systems. Oneida Air Systems reserves the right to inspect and investigate all returned products before Buyer's claim is settled. All products returned for a refund must be unused and resalable and purchased within the last 30 days. There are no refunds on flex hose or custom made components. There will be a 25% restocking fee applied to any returned items. Buyer must call and obtain a Return Material Authorization Number (RMA #) prior to making a return. All merchandise must be shipped to us prepaid.