

Specifications

JDN Air Hoists PROFI

PROFI 25 TI - PROFI 100 TI

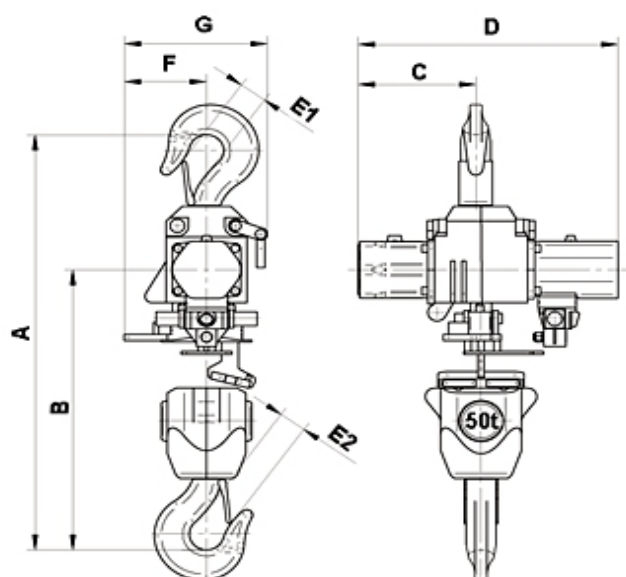

| Dimensions | | 25 TI | 37 TI | 50 TI | 100 TI |
|------------------------------|-------|--------------------|-------|-------|--------|
| A min. headroom ¹ | inch. | 50.47 ² | 55.12 | 66.93 | 86.61 |
| | mm | 1282 ² | 1400 | 1700 | 2200 |
| B | inch. | 37.32 | 34.21 | 45 | 58.1 |
| | mm | 948 | 869 | 1144 | 1475 |
| C | inch. | 15.5 | 14.84 | 17.52 | 28.9 |
| | mm | 393 | 377 | 445 | 734 |
| D | inch. | 33 | 31.97 | 38.58 | 59.25 |
| | mm | 839 | 812 | 980 | 1505 |
| E1 | inch. | 2.9 | 4.05 | 4.05 | 4.7 |
| | mm | 75 | 103 | 103 | 120 |
| E2 | inch. | 2.9 | 4.05 | 4.05 | 4.7 |
| | mm | 75 | 103 | 103 | 120 |
| F | inch. | 18.35 | 20.39 | 12.2 | 17.32 |
| | mm | 466 | 518 | 310 | 440 |
| G maximum width | inch. | 24 | 29.33 | 21.22 | 30.2 |
| | mm | 610 | 745 | 539 | 767 |

¹ Chain containers increase the headroom.

² Shipyards version with extended headroom. Please consult J.D. Neuhaus.

| Type | | 25 TI | 37 TI | | 50 TI | | 100 TI |
|---------------------------|-----|-------|-------|----|-------|----|--------|
| Air pressure | psi | 85 | 65 | 85 | 65 | 85 | 85 |
| | bar | 6 | 4 | 6 | 4 | 6 | 6 |
| Capacity | mt | 25 | 37.5 | | 50 | | 100 |
| Number of chain standards | | 2 | 3 | | 4 | | 4 |
| Motor output | kW | 6 | 4 | 6 | 4 | 6 | 10 |

| | | | | | | | | |
|---------------------------------------|-------------------------|---------------------|---------|---------|-------|---------|-------|-----------|
| Lifting speed | without load | ft/min | 7.54 | 1.14 | 3.6 | 2.29 | 4.26 | 2.29 |
| | | m/min | 2.3 | 1.1 | 1.6 | 0.7 | 1.3 | 0.7 |
| | at full load | ft/min | 3.6 | 1.31 | 2.13 | 1.14 | 0.98 | 1.14 |
| | | m/min | 1.1 | 0.4 | 0.65 | 0.3 | 0.45 | 0.35 |
| Lowering speed | at full load | ft/min | 6.23 | 3.28 | 4.92 | 2.95 | 4.59 | 2.62 |
| | | m/min | 1.9 | 1.0 | 1.5 | 0.9 | 1.4 | 0.8 |
| Air consumption | at full load - lifting | cfm | 194.8 | 166.4 | 194.8 | 166.4 | 194.8 | 389.5 |
| | | m ³ /min | 5.5 | 4.7 | 5.5 | 4.7 | 5.5 | 11 |
| Air consumption | at full load - lowering | cfm | 230 | 194.8 | 230 | 198.2 | 230 | 424.9 |
| | | m ³ /min | 6.5 | 5.5 | 6.5 | 5.6 | 6.5 | 12 |
| Air connection | | inch. | G 1 | G 1 | | G 1 | | G 1 ½ |
| Hose dimension (ø inside / ø outside) | | mm | 25/39 | 25/39 | | 25/39 | | 35/51 |
| Weight with standard lift | | lbs | 1098 | 1936 | | 1885 | | 5423 |
| | | kg | 498 | 880 | | 855 | | 2460 |
| Chain dimension | | mm | 22 x 66 | 22 x 66 | | 22 x 66 | | 31.5 x 90 |
| Weight of chain | | lbs/ft | 7.25 | 7.25 | | 7.25 | | 14.3 |
| | | kg/m | 10.8 | 10.8 | | 10.8 | | 21.3 |
| Standard lift | | feet | 10 | 10 | | 10 | | 10 |
| | | m | 3 | 3 | | 3 | | 3 |

Issue 06.09.2004

4 bar versions for Profi 25 TI and 100 TI on request.