

## PathWay® Model 7198 Dual Channel BNC A/B Switch with Telnet

- **Ideal for switching BNC connections remotely via the internet.**

### INTRODUCTION

The PathWay® Model 7198 Dual Channel BNC A/B Switch with Telnet allows the user the capability of sharing a single port interface device connected to the "COMMON" port among two other devices connected to the "A" and "B" ports for each channel. Remote Control access can be accomplished using an Ethernet 10/100BASE-T connection and either Telnet commands or graphical user interface. The Model 7198 dimensions are 19"W x 1.75"H x 8"D.

### FEATURES:

- Each of two channels allows quick connection to any one of two devices from one COMMON device.
- Both Center and Shell of all BNC ports are switched.
- The switch ports are transparent to all data.
- Two independent switch channels.
- Eliminates the need to plug and unplug cables.
- Transparent to data speed and format.
- Local control via front-panel pushbuttons.
- Remote Control of the switch position from a 10/100-Base-T LAN Ethernet environment.
- Remote Control Telnet command interface allows the user to control switch position, lockout front panel operations and obtain switch status with gang commands allowed.
- IP addressable.
- Remote access is password protected.
- Front panel LED's display current position and power status.
- Retains last switch position even in the event of power loss and continues to pass data.
- Attractive anodized black box packaging provides EMI/RFI shielding.
- Custom length BNC cables available for your switch installation.



### SPECIFICATIONS:

**PORT CONNECTORS:** (3) BNC (F) connectors labeled A, B and COMMON for each Channel.

**FRONT PANEL CONTROL:** (2) Manual pushbuttons allow local switching.

**DISPLAY:** (4) Front panel LED's display switch position and power status.

**REMOTE CONTROL:** (1) RJ45 female connector on rear panel accepts 10/100 Base-T LAN access Ethernet for Remote Control Operation.

**POWER:** UL approved 120VAC, 60 Hz wall mount power module supplies 12 VDC, 500mA to the unit.

**DIMENSIONS:** Rackmount 19.0" W x 1.75" H x 8.0" D. (48.3 x 4.4 x 20.3 cm), (1U rack height).

**WEIGHT:** Approximately 4.5 lbs. (2.0 Kg)

### OPTION: WIDE RANGE POWER MODULE

(Cat No 517277) CE and UL listed table mount power module, 100VAC/240VAC, 50Hz/60Hz in place of standard 115VAC or 120VAC power module. Ideal for international applications.

### Model 7198 Application

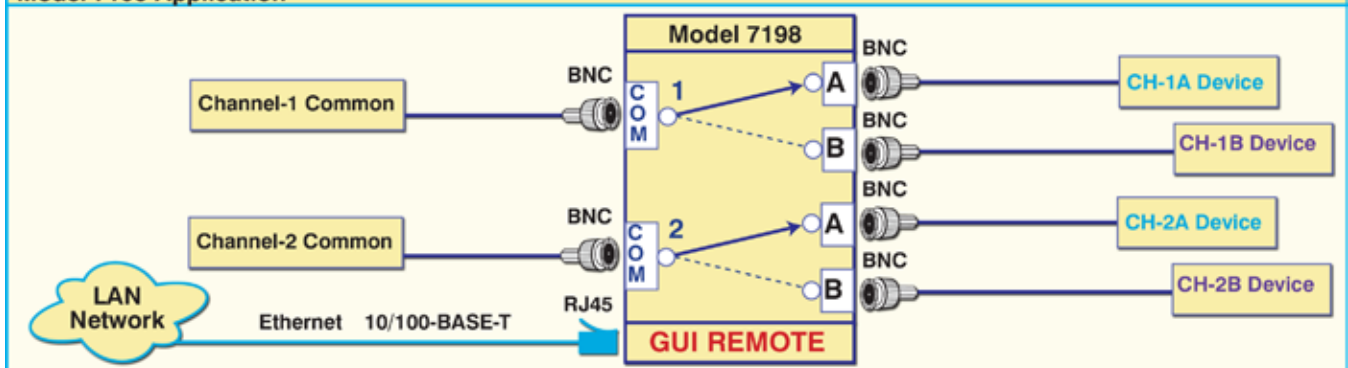

### Suggested cables for use with Model 7198 Switch.

Part Number	Description	Unit Price
990136-006	RG58 Coaxial Cable, 50 ohm, 6 ft.	15.80
990136-010	RG58 Coaxial, 50 ohm, 10 ft.	17.00
890426-006	Thinnet RG58 Coaxial Cable, 50 ohm, 6 ft.	16.80
890426-010	Thinnet RG58 Coaxial Cable, 50 ohm, 10 ft	18.00