

PathWay® Model 7423 RJ45 Cat5 A/B/C/D Switch with Serial Remote Control port, Board Only

INTRODUCTION

The PathWay® Model 7423 RJ45 A/B/C/D Switch with Serial Remote Control, Board Only, provides the user with local and remote control functionality. It allows the user to share a single RJ45 interface device connected to the COMMON port among four other devices connected to the "A", "B", "C", and "D" ports. Remote access can be accomplished by RS-232 commands sent via the Serial Remote Control Port. Users can remotely monitor status, control switch functions, and lockout the front panel pushbuttons.

FEATURES:

- The switch ports are transparent to all data.
- Four signals switched. Pairs (1 & 2) (3 & 6).
- All switched signals are passed via copper contact relays that maintain their position and continuity even in the event of a power loss.
- Board mounted pushbutton control or Remote ASCII Command access through the serial port.
- Board mounted LED's display the current switch position and power status.
- Remote Control Lockout of pushbuttons.
- Remote Control query of current switch position.
- Meets Cat 5 compliance standards.

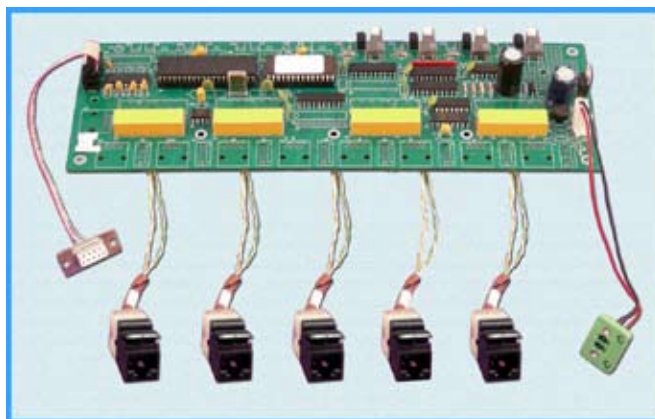

SPECIFICATIONS:

PORT CONNECTORS: (5) RJ45 (F) connectors tagged A, B, C, D, and COMMON.

MANUAL CONTROLS: (4) Manual pushbuttons allow local switching.

DISPLAY: (4) LED's display switch position and power status.

REMOTE CONTROL: (1) DB9 female connector on rear panel accepts ASCII RS232 Serial Data for remote control operation.

POWER: UL approved 110 /120 VAC, 60 Hz wall mount power module supplies 12 VAC, 500mA to the unit.

DIMENSIONS: (Board), 10.5" W x 1.5" H x 3.5" D.

WEIGHT: Approximately 0.5 lbs

Model 7423 Application

