

SWING CLAMPS - MINIATURE

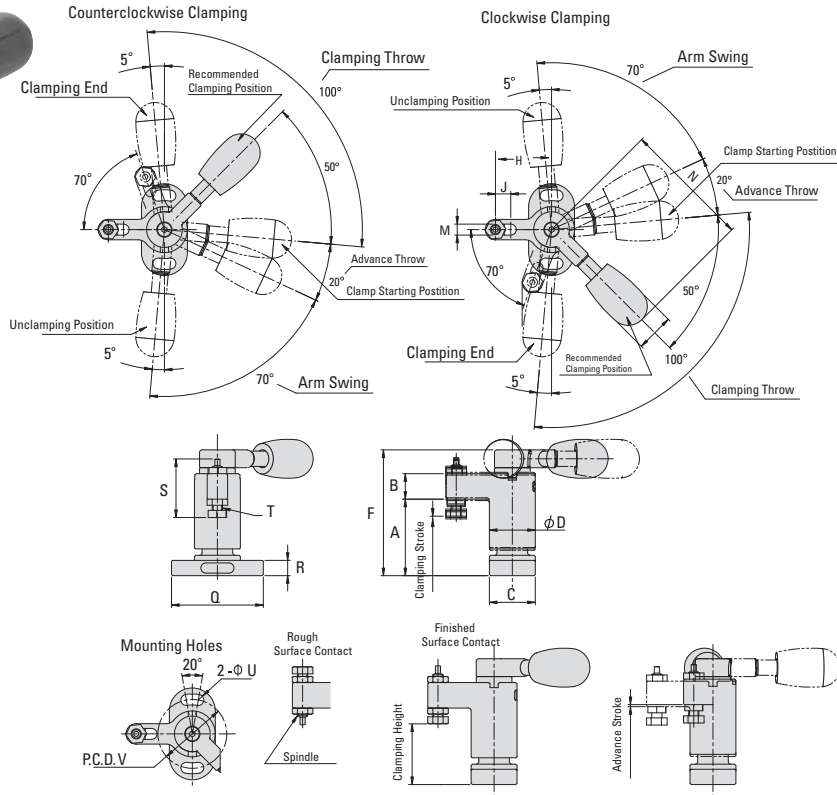

How To Use

Load the work piece with the clamp arm out of the way.

Turn the handle to set the arm over the work piece and clamp to final position.

These miniature swing clamps swing into position and clamp straight down onto the work piece for direct downward pressure. The arm swings completely out of the way to allow for easy loading and unloading of the work piece. Ideal for repetitive clamping operations. Comes with a contact bolt that can be reversed for finished or rough surfaces. Mounts from the top with two mounting holes. The 100 series provide 247 lbs of clamping force, the 150 series provides 404 lbs of clamping force. Part numbers ending with R have a clockwise clamping direction, part numbers ending in L have a counter clockwise clamping direction. Maximum load to operate the handle is 22 lbs. for the 100 series and 33 lbs. for the 150 series. The body, handle and spindle are made from SAE-1045 alloy steel. The clamp arm and cam shaft is made from SAE-4140 alloy steel. Parts are heat treated with black oxide finish. Handle is black plastic.

Part #	Clamping Height		Clamping Stroke	Advance Stroke
	Finished Surface	Rough Surface		
QLSWC100R	22.3 - 25.3	21.9 - 24.9	1.0	0.8
QLSWC100L	22.3 - 25.3	21.9 - 24.9	1.0	0.8
QLSWC150R	30.6 - 34.0	31.5 - 34.9	1.4	1.1
QLSWC150L	30.6 - 34.0	31.5 - 34.9	1.4	1.1

Part #	A	B	C	D	F	H	J	M	N	Q	R	S	T	U	V	P.C.D.*
	mm	mm	mm	mm	mm	mm	mm	mm	mm	mm	mm	mm	mm	mm	mm	mm
QLSWC100R	30	10	18	18	49	22	6	4.3	50	36	6	22.8	M4X0.7	4.3	27	
QLSWC100L	30	10	18	18	49	22	6	4.3	50	36	6	22.8	M4X0.7	4.3	27	
QLSWC150R	40	14	23	23	66	30	8	5.3	63	45	8	28.5	M5X0.8	5.3	34	
QLSWC150L	40	14	23	23	66	30	8	5.3	63	45	8	28.5	M5X0.8	5.3	34	

*Pitch Circle Diameter

MARKER PLATES

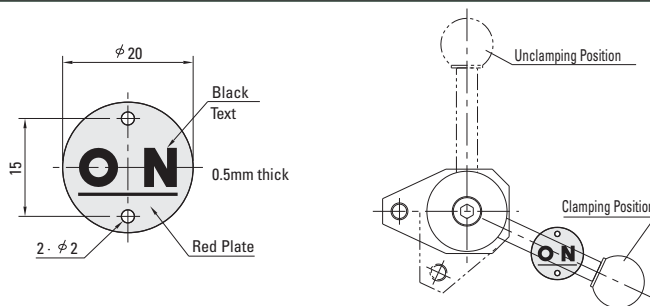
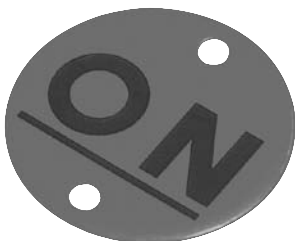

These aluminum marker plates are used to mark the handle position in the clamping mode. Pressure sensitive adhesive on the backside. 2mm holes allow for riveting. Color is red.

PART #
QLST-ON